

CAPACITY:

20,000-65,000 BTUH (5.8kW-19kW).
50°F (10°C) -135°F (57°C) Ambient temperature.
Variation in capacity dependent on condenser sizing,
type of refrigerant, ambient operating temperature and
return air temperature.

MOUNTING CONFIGURATIONS:

Wall mounting, Roof mounting or ceiling hung mounting.

WELDED FRAME CONSTRUCTION:

Heavy gauge 304 stainless steel frame.

EVAPORATOR COIL:

Aluminum fin, copper tube. 8 fins per inch (3.2mm).
Heavy gauge hardened fin stock 0.0095" (0.241mm) thickness.
Epoxy coated.

BLOWER WHEEL / MOTOR:

Motorized impeller. Backward curved.

VOLTAGES:

208-230/460/575/3/60Hz, VAC
380-415/3/50Hz VAC
Single phase available on limited models up to 3 tons (10kW).

REFRIGERANT FLOW CONTROL:

Balance port thermostatic expansion valve.

HEATER:

Standard 4kW (13,660 BTUH.)
For additional kW please consult factory.

MECHANICAL AIR FILTER:

Polyester fiber cleanable filter.

REFRIGERANTS:

R-134a

WEIGHT:

212 LBS. (96kg.)

AIR FLOW:

1200 CFM 50/60Hz



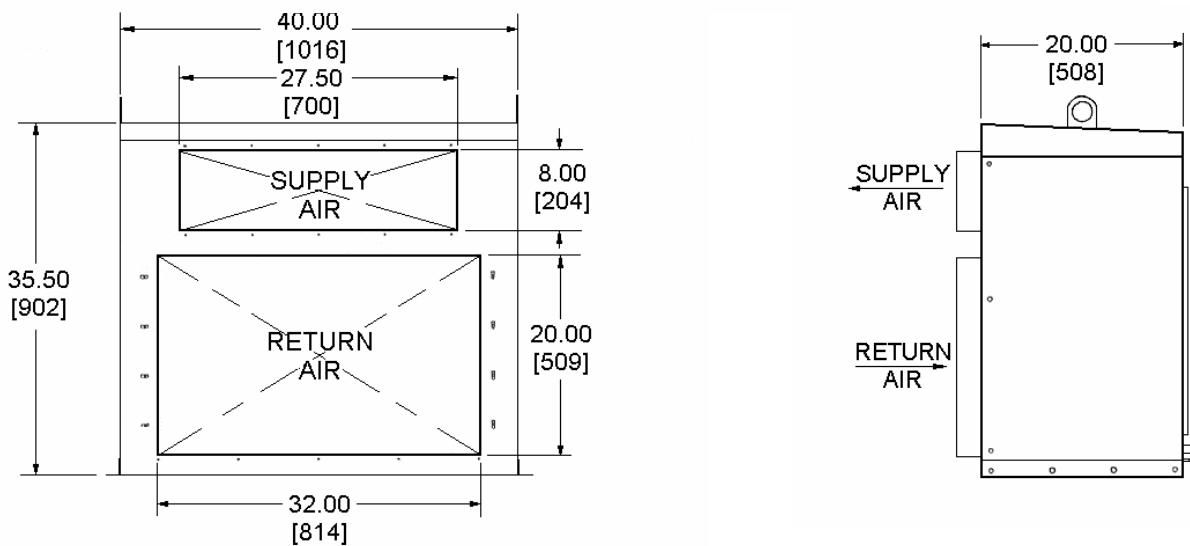
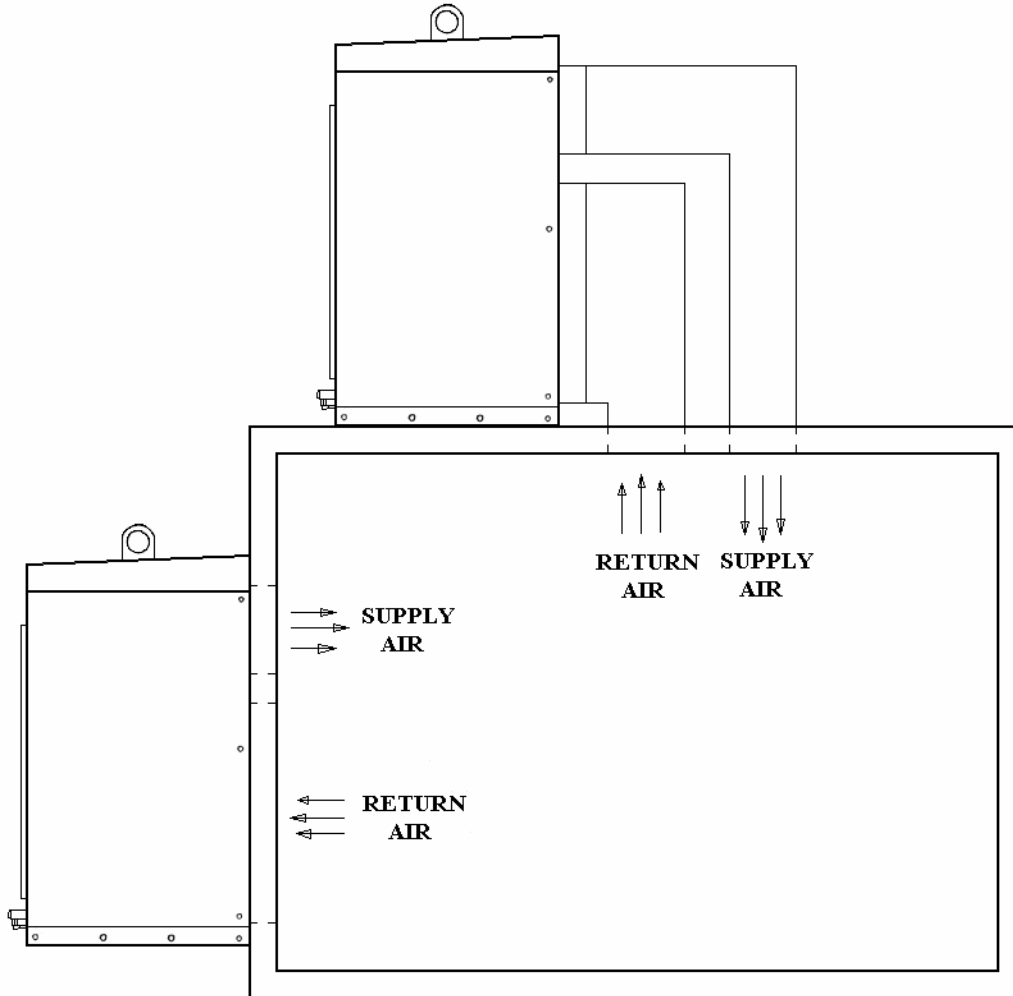

8685 Station Street · P.O. Box 90 · Mentor, OH 44061-0090 USA

Phone: 800-321-3638 (North America) or Call (440) 255-9333 · Fax: (440) 255-6427 · Email: solutions@lintern.com

www.lintern.com